

Doc. A/81
30 July 2003

ATSC Direct-to-Home Satellite Broadcast Standard

Advanced Television Systems Committee

1750 K Street, N.W.

Suite 1200

Washington, D.C. 20006

www.atsc.org

The Advanced Television Systems Committee, Inc., is an international, non-profit organization developing voluntary standards for digital television. The ATSC member organizations represent the broadcast, broadcast equipment, motion picture, consumer electronics, computer, cable, satellite, and semiconductor industries.

Specifically, ATSC is working to coordinate television standards among different communications media focusing on digital television, interactive systems, and broadband multimedia communications. ATSC is also developing digital television implementation strategies and presenting educational seminars on the ATSC standards.

ATSC was formed in 1982 by the member organizations of the Joint Committee on InterSociety Coordination (JCIC): the Electronic Industries Association (EIA), the Institute of Electrical and Electronic Engineers (IEEE), the National Association of Broadcasters (NAB), the National Cable Television Association (NCTA), and the Society of Motion Picture and Television Engineers (SMPTE). Currently, there are approximately 140 members representing the broadcast, broadcast equipment, motion picture, consumer electronics, computer, cable, satellite, and semiconductor industries.

ATSC Digital TV Standards include digital high definition television (HDTV), standard definition television (SDTV), data broadcasting, multichannel surround-sound audio, and satellite direct-to-home broadcasting.

Table of Contents

1. SCOPE	6
2. REFERENCES	6
2.1 Normative references	6
2.2 Informative References	7
3. DEFINITIONS	7
3.1 Compliance Notation	7
3.2 Acronyms and Abbreviations	7
4. SYSTEM OVERVIEW	9
4.1 Transmission System	9
4.2 Integrated Receiver Decoder System	11
5. TRANSMISSION SUBSYSTEM	11
6. TRANSPORT SUBSYSTEM SPECIFICATION.....	11
6.1 Video T-STD	12
6.2 Audio T-STD	12
6.3 Identification of MPEG-2 Private Ranges	12
6.3.1 MPEG-2 Registration Descriptor	12
6.3.2 Program Identifier	12
6.3.3 Audio Elementary Stream Identifier	12
6.3.4 Other Program Element Identifiers	12
6.4 Constraints on PSI	13
6.5 PES Constraints	13
6.5.1 Audio PES Constraints	14
6.6 Specification of ATSC Private Data	14
6.7 Descriptors	14
6.7.1 Video Stream Descriptor	15
6.8 Audio Constraints	15
7. VIDEO SUBSYSTEM SPECIFICATION.....	15
7.1 Possible Video Inputs	15
7.2 Source Coding Specification	15
7.3 Constraints with Respect to ISO/IEC 13818-2 Main Profile	15
7.3.1 Sequence Header Constraints	16
7.3.2 Compression Format Constraints	16
7.3.3 Sequence Extension Constraints	17
7.3.4 Sequence Display Extension Constraints	18
7.3.5 Picture Coding Constraints	18

7.3.6	MPEG-2 Still Pictures	18
7.4	Bit Stream Specifications Beyond MPEG-2	19
7.4.1	Encoding and Transport of Advanced DTV Captions	19
7.4.2	Encoding and Transport of NTSC Closed Captions	19
7.4.3	Encoding of Other NTSC VBI Data	19
7.4.4	Encoding and Transport of Bar Data	19
7.4.5	Encoding and Transport of Active Format Description Data	19
8.	AUDIO SUBSYSTEM SPECIFICATION	19
8.1	Constraints with Respect to ATSC Standard A/52A	19
8.1.1	Sampling Frequency	19
8.1.2	Audio Coding Modes	19
8.2	MPEG-1 Layer II Audio	20
9.	PSIP SYSTEM	20
9.1	Overview	20
9.2	Data Structure	21
9.2.1	Table Format	21
9.3	Extensibility	23
9.4	User Private Ranges	23
9.4.1	table_id values in the range 0x40 through 0xBF	23
9.5	Reserved Fields	23
9.6	Table Hierarchy and Structure Requirements	24
9.7	Requirements for Satellite Broadcast	25
9.8	Code points defined in this Standard	26
9.9	Specifications	26
9.9.1	Satellite Virtual Channel Table (SVCT)	26
9.9.2	Aggregate Event Information Tables (AEIT)	31
9.9.3	Aggregate Extended Text Tables (AETT)	34
9.9.4	Master Guide Table (MGT)	36
9.9.5	Core Descriptors	37
9.9.6	PSIP STD Model Constraints	37
10.	CONDITIONAL ACCESS SUBSYSTEM	38

Tables and Figures

Table 7.1 Standardized Video Input Formats	15
Table 7.2 Sequence Header Constraints	16
Table 7.3 Compression Format Constraints	17
Table 7.4 Sequence Extension Constraints	18
Table 7.5 Sequence Display Extension Constraints	18
Table 8.1 Audio Coding Mode	20
Table 9.1 Generic Table format used in Satellite PSIP	21
Table 9.2 Table ID Ranges and Values (Informative)	22
Table 9.3 Bit Stream Syntax for the Satellite Virtual Channel Table	27
Table 9.4 Modulation Modes	29
Table 9.5 Polarization Coding	30
Table 9.6 FEC_inner Coding	30
Table 9.7 Aggregate Event Information Table format	32
Table 9.8 Aggregate Extended Text Table Format	35
Table 9.9 ETM ID	36
Table 9.10 MGT Table Types for Satellite Application	36
Table 9.11 List of Descriptors for Satellite PSIP Tables	37
Table 9.12 Maximum cycle time for the STT, MGT, SVCT and RRT	38
Table 9.13 Maximum Rate for Each PSIP Packet Stream	38
Figure 4.1 Overview of the Transmission System.	10
Figure 4.2 Functional block diagram of an IRD system.	11
Figure 9.1 Table hierarchy for Satellite PSIP	24

ATSC Direct-to-Home Satellite Broadcast Standard

1. SCOPE

This document describes the emission system for ATSC Direct-to-Home (DTH) Satellite Broadcast System. This specification defines extensions to audio, video, transport, and PSIP subsystems as defined in ATSC Standards A/53B and A/65A. The emission system defined in this document includes carriage of data broadcasting as defined in ATSC Standard A/90 without requiring extensions. Furthermore, transmission and conditional access subsystems are not defined, allowing service providers to use existing subsystems.

2. REFERENCES

2.1 Normative references

The following documents contain provisions which, in whole or in part, through reference in this text, constitute provisions of this Standard. At the time of publication, the editions indicated were valid. All standards are subject to revision and amendment, and parties to agreements based on this Standard are encouraged to investigate the possibility of applying the most recent editions of the documents listed below.

1. ANSI/SCTE 20 2001: Standard Methods for Carriage of Closed Captions and Non-Real Time Sampled Video.
2. ANSI/SCTE 21 2001: Standard for Carriage of NTSC VBI Data in Cable Digital Transport Streams.
3. ATSC A/52A (2001): "Digital Audio Compression (AC-3)."
4. ATSC A/53B with Amendment 1: "ATSC Digital Television Standard."
5. ATSC A/63 (1997): "Standard for Coding 25/50 Hz Video."
6. ATSC A/65B (2003): "Program and System Information Protocol (PSIP) for Terrestrial Broadcast and Cable."
7. ATSC A/80 (2000): "Modulation and Coding Requirements for Digital TV (DTV) Applications Over Satellite."
8. ATSC T3-580 (2002): "Proposed Standard: Amendment 2 to A/53B."
9. EIA/CEA-608-B (2000): Line 21 Data Services.
10. ANSI/SCTE 54 2002A: Digital Video Service Multiplex and Transport System Standard for Cable Television.
11. EIA/CEA-766-A (2000): U.S. and Canadian Rating Region Tables (RRT) and Content Advisory Descriptors for Transport of Content Advisory Information Using ATSC A/65-A Program and System Information Protocol (PSIP).
12. EIA-708-B (1999): Digital Television (DTV) Closed Captioning.
13. EN 300 421 V1.1.2 (1997-08): "Digital Video Broadcasting (DVB); Framing structure, channel coding and modulation for 11/12 GHz satellite services."
14. ISO 639.2 (1998): Code for the representation of names of languages Part 2: Alpha-3 code.

15. ISO/IEC 10646-1: 2000: Information technology—Universal Multiple-Octet Coded Character Set (UCS)—Part 1: Architecture and Basic Multilingual Plane.
16. ISO/IEC 13818-2: 2000/Cor. 1: 2001 (E) MPEG-2 Video Technical Corrigendum.
17. ISO/IEC IS 13818-1 (2000): Information Technology—Generic coding of moving pictures and associated audio—Part 1: Systems.
18. ISO/IEC IS 13818-2 (2000): Information Technology—Generic coding of moving pictures and associated audio—Part 2: Video.
19. The Unicode Standard, Version 3.0, The Unicode Consortium, Addison-Wesley Pub., ISBN 0201616335.

2.2 Informative References

20. ANSI/SCTE 07 2000: Digital Video Transmission System Standard for Cable Television.
21. ANSI/SCTE 43 2002: Digital Video Systems Characteristics Standard for Cable Television.
22. ANSI/SCTE 65 2002: Service Information Delivered Out-of-Band for Digital Cable Television.
23. ATSC A/56 (1996): “System Information for Digital Television,”
24. ATSC A/70 (2000): “Conditional Access System for Terrestrial Broadcast.”
25. ATSC A/90 (2000): “Data Broadcast Standard.”
26. ETSI EN 300 468 V1.4.1 (2000-11): “Digital Video Broadcasting (DVB); Specification for Service Information (SI) in DVB systems.”
27. ISO/IEC 8859, Information Processing—8-bit Single-Octet Coded Character Sets, Parts 1 through 10.
28. ISO/IEC IS 11172-3, International Standard (1993), MPEG-1 Audio.
29. ITU-R BT.601-5: Encoding parameters of digital television for studios.
30. ITU-R BT.709: Basic Parameter Values for the HDTV Standard for the Studio and for International Programme Exchange.
31. ITU-T J.83B: Digital Video Transmission Standard for Cable Television.
32. SMPTE 274M (1995): Standard for television, 1920 x 1080 Scanning and Interface.
33. SMPTE 296M (1997): Standard for television, 1280 x 720 Scanning, Analog and Digital Representation, and Analog Interface.

3. DEFINITIONS

3.1 Compliance Notation

As used in this document, “shall” denotes a mandatory provision of the standard. “Should” denotes a provision that is recommended but not mandatory. “May” denotes a feature whose presence does not preclude compliance, which may or may not be present at the option of the implementor.

3.2 Acronyms and Abbreviations

The following acronyms and abbreviations are used within this specification:

AEIT	aggregate event information table
AETT	aggregate extended text table
ASTD	ancillary service target decoder
ATSC	Advanced Television Systems Committee
BPSK	binary phase shift keying
bslbf	bit serial, leftmost bit first
CA	conditional access
CAT	conditional access table
CRC	cyclic redundancy check
CVCT	cable virtual channel table
DET	data event table
DSM-CC	digital storage media command and control
DST	data service table
DTS	decoding time stamp
DVB	Digital Video Broadcasting
DVS	Digital Video Subcommittee
EA	emergency alert
ECM	entitlement control message
EIT	event information table
ES	elementary stream
ETM	extended text message
ETT	extended text table
GPS	Global Positioning System
IEC	International Electrotechnical Commission
ISO	International Organization for Standardization
MGT	master guide table
MPEG	Moving Picture Experts Group
MRD	MPEG registration descriptor
PAT	program association table
PES	packetized elementary stream
PID	packet identifier
PMT	program map table
PSI	program specific information
PSIP	Program and System Information Protocol
PTS	presentation time stamp
OQPSK	offset quadrature phase shift keying
QAM	quadrature amplitude modulation
QPSK	quadrature phase shift keying

rpchof	remainder polynomial coefficients, highest order first
RRT	rating region table
SCTE	Society of Cable Telecommunications Engineers
SI	service information
STD	system target decoder
STT	system time table
TS	transport stream
T-STD	transport stream system target decoder
TVCT	terrestrial virtual channel table
uimsbf	unsigned integer, most significant bit first
UTC	coordinated universal time ¹
VBV	video buffering verifier

4. SYSTEM OVERVIEW

The Satellite Broadcast System comprises of two major subsystems: 1) the Transmission System and 2) an Integrated Receiver Decoder, commonly referred as a Set Top Box (STB).

4.1 Transmission System

The transmission system comprises an Emission Mux, a Modulator/Encoder, and a Transmitter. The Emission Mux requirements are discussed in this document. Specifications for the Modulator/Encoder and the Transmitter were deemed not necessary for the purposes of this standard, and are left for Service Provider to develop.

¹ Because unanimous agreement could not be achieved by the ITU on using either the English word order, CUT, or the French word order, TUC, a compromise to use neither was reached.

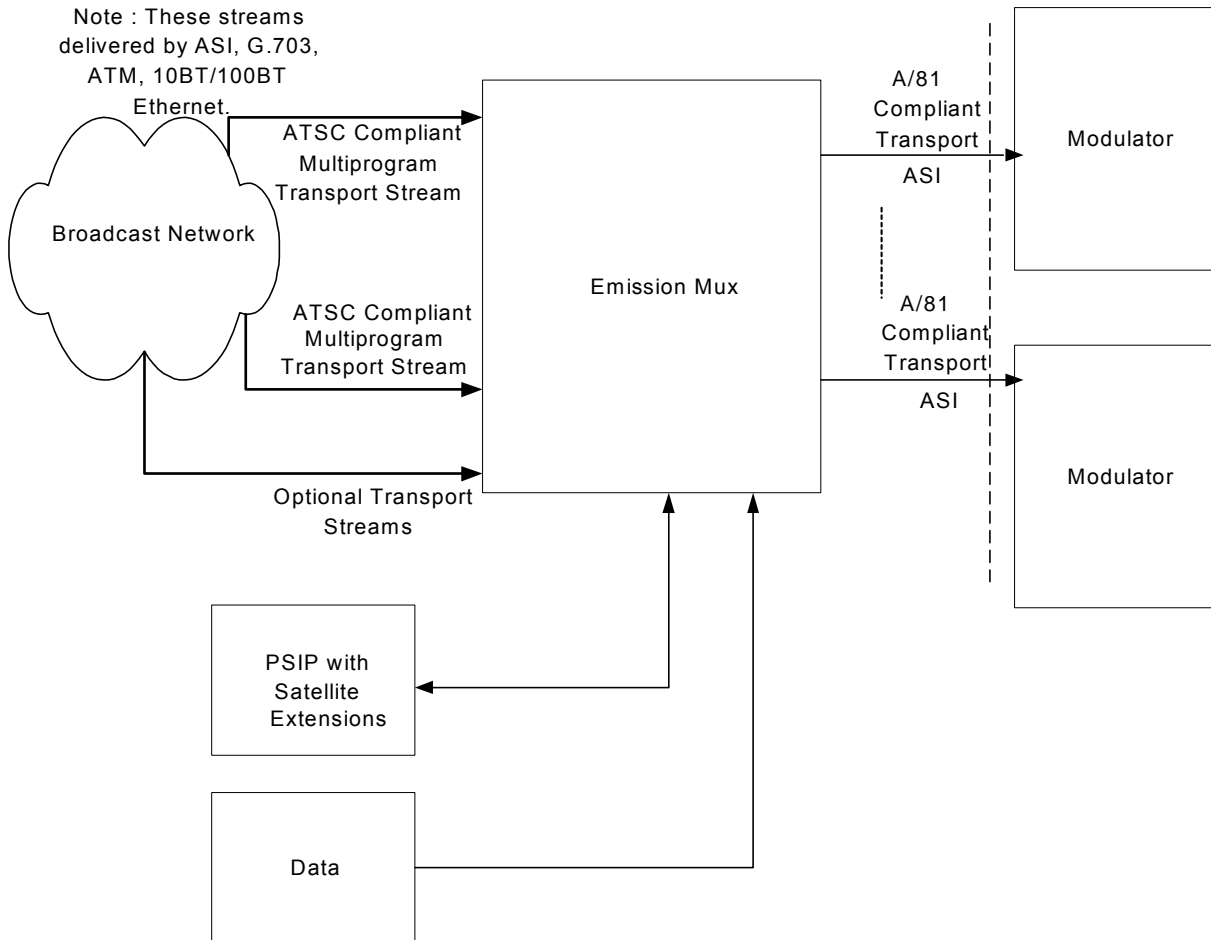

Figure 4.1 Overview of the Transmission System.

Figure 4.1 shows a functional block diagram of a transmission system. The Emission Mux accepts and combines:

- ATSC multi-program transport streams (A/53B, A/65B, A/70, and A/90 protocols) from different sources
- Satellite extensions to PSIP

Additionally, the Emission Mux may accept:

- MPEG Compliant (non-ATSC) transport streams
- Data streams such as A/90 and DVB data broadcast

Each multi-program transport stream output from the Emission Mux to a modulator shall conform with:

- Transport, audio, and video format extensions defined for satellite delivery in this standard.
- System Information with all the normative elements from A/65B (PSIP) and Satellite extensions such as the Satellite VCT defined in this standard.

Transport Streams at the output of the Emission Mux may also carry additional information to support delivery system specific needs (such as DVB-SI [26], A/56 [23], control data, EIA-

608B captions using ANSI/SCTE 20 2001 [1], and MPEG-1 Layer 2 audio [28]). When present, such information shall not conflict with the code points used in this standard.

4.2 Integrated Receiver Decoder System

A functional block diagram of an Integrated Receiver Decoder (IRD) system is depicted in Figure 4.2. This system demodulates and decodes audio, video, and data streams compatible with the transmission system described in Section 4.1.

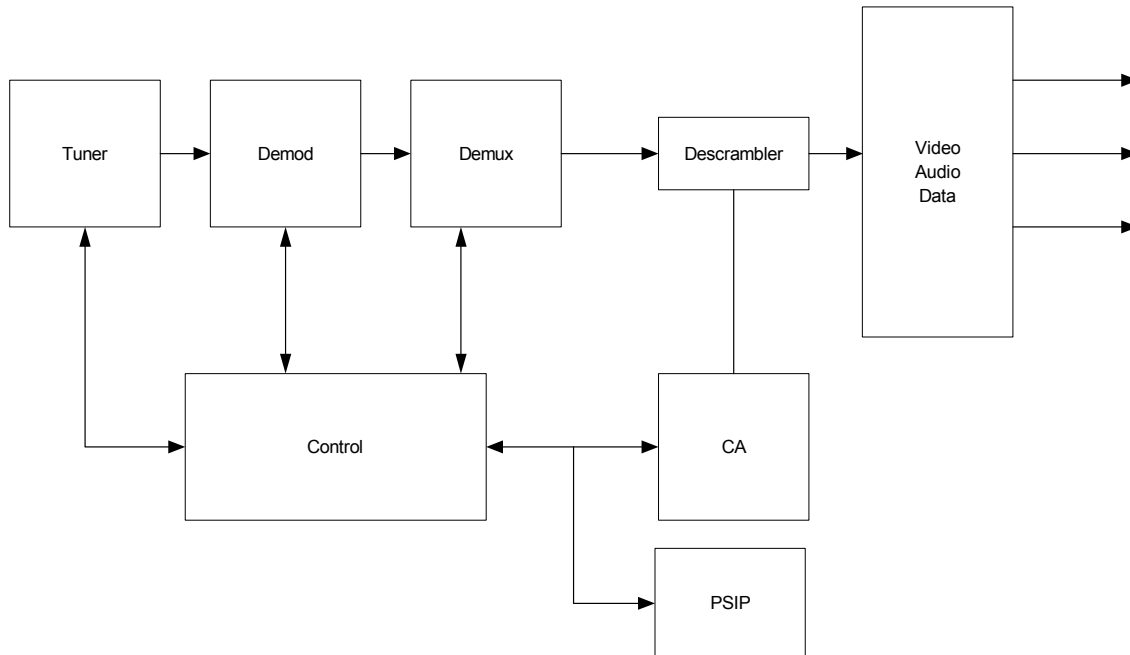

Figure 4.2 Functional block diagram of an IRD system.

5. TRANSMISSION SUBSYSTEM

This Standard does not specify the transmission element of the delivery system. Service providers may use existing or future delivery systems for transmission. However, the transport, video, audio, and PSIP must comply with the specifications given in the following sections.

6. TRANSPORT SUBSYSTEM SPECIFICATION

This section constitutes the normative specification for the transport system of the Service Multiplex and Transport System Standard for the ATSC DTH Satellite Specification. The transport sub-system shall comply with the transport stream definition of the MPEG-2 Systems standard as specified in ISO/IEC 13818-1 and shall be further constrained as specified herein.

6.1 Video T-STD

The video Transport Stream System Target Decoder (T-STD) shall comply with Section 2.4.2.3 of ISO/IEC 13818-1 and shall follow the constraints for the level encoded in the video elementary stream.

6.2 Audio T-STD

The audio T-STD shall comply with section 3.6 of Annex A of ATSC standard A/52A.

6.3 Identification of MPEG-2 Private Ranges

ATSC defines code points in the MPEG-2 user private range and may define code points private to ATSC users within this range.

6.3.1 MPEG-2 Registration Descriptor

Under circumstances as defined Section 6.3.2 – 6.3.4, this Standard uses the MPEG-2 Registration Descriptor described in Section 2.6.8 and 2.6.9 of ISO/IEC 13818-1 [17] to identify the contents of programs and program elements to decoding equipment. No more than one MPEG-2 Registration Descriptor shall appear in any given descriptor loop.

6.3.2 Program Identifier

Programs which conform to this specification may be identified by the format identifier carried in the `registration_descriptor` in the Program Map Table (PMT) detailed in Section 2.4.4.8 of ISO/IEC 13818-1 [17]. The identifier shall be coded according to Section 2.6.8 and when present shall have a value of 0x5331 3441 (“S14A” in ASCII) for programs that comply to ATSC Satellite Broadcast. Optionally, some of the programs may carry the `registration_descriptor` with `format_identifier` values of 0x4741 3934 (“GA94” in ASCII) for programs that comply to ATSC terrestrial broadcast, 0x5343 5445 (“SCTE” in ASCII) for programs that comply with ANSI/SCTE 54 [10], and identifiers for programs that comply to DVB standards. The MRD containing one of these format identifiers shall only be present in the outer loop of the PMT and shall apply to all the elementary streams within the program. Only one `registration_descriptor` shall be present in the outer loop even though a mix of registration descriptors can occur within a multi-program transport stream.

6.3.3 Audio Elementary Stream Identifier

Audio elementary streams that conform to ATSC standards may use an MPEG-2 Registration Descriptor (as defined in Section 2.6.8 and 2.6.9 of ISO/IEC 13818-1 [17]). When present, the MPEG-2 Registration Descriptor shall be placed in the descriptor loop immediately following the `ES_info_length` field in the `TS_program_map_section()` for each program element of `stream_type` 0x81 (AC-3 audio). The `format_identifier` field of the MPEG-2 Registration Descriptor shall have a value of 0x4143 2D33 (“AC-3” in ASCII).

6.3.4 Other Program Element Identifiers

Any program element carrying content not described by an approved ATSC standard shall be identified with an MPEG-2 Registration Descriptor (as defined in Section 2.6.8 and 2.6.9 of ISO/IEC 13818-1 [17]). The `format_identifier` field of the MPEG-2 Registration Descriptor shall be registered with the SMPTE Registration Authority, LLC. The descriptor shall be placed in the

descriptor loop immediately following the `ES_info_length` field in the `TS_program_map_section()` for each such non-standard program element.

The presence of an MPEG-2 Registration Descriptor in any descriptor loop shall not affect the meaning of any other descriptor(s) in the same descriptor loop. The ATSC Private Information Descriptor shall be the standard method to carry descriptor-based information associated with a private entity.

An MPEG-2 Registration Descriptor shall be placed in the descriptor loop immediately following the `ES_info_length` field in the `TS_program_map_section()` for each program element having a `stream_type` value in the ATSC-user private range, 0xC4 to 0xFF, to establish the private entity associated with that program element.

6.4 Constraints on PSI

The program constituents for all programs are described in the PSI according to ISO/IEC 13818-1 [17]. The following constraints shall apply to the PSI information:

- Transport Stream packets identified by a particular `PMT_PID` value shall be constrained to carry only one program definition, as described by a single `TS_program_map_section()`.
- The Transport Stream shall be constructed such that the time interval between the byte containing the last bit of the `TS_program_map_section()` containing television program information and successive occurrences of the same `TS_program_map_section()` shall be less than or equal to 400 milliseconds.
- The `program_number` values shall be associated with the corresponding `PMT_PIDs` in the Program Association Table (PAT). The Transport Stream shall be constructed such that the time interval between the byte containing the last bit of the `program_association_section()` and successive occurrences of the `program_association_section()` shall be less than or equal to 100 milliseconds. However, when `program_association_section()`s, `CA_section()`s, and `TS_program_map_section()`s are approaching their maximum allowed sizes, the potential exists to exceed the 80,000 bps rate specified in ISO/IEC 13818-1 Sec. 2.4.2.3. In cases where the table section sizes are such that the 100 millisecond repetition rate of the `program_association_section()` would cause the 80,000 bps maximum rate to be exceeded, the time interval between the byte containing the last bit of the `program_association_section()` may be increased but in no event shall exceed 140 milliseconds, so that under no circumstances the limit of 80,000 bps is exceeded.
- Adaptation headers shall not occur in TS packets identified by a `program_map_PID` value for purposes other than for signaling with the `discontinuity_indicator` that the `version_number` (Section 2.4.4.5 of ISO/IEC 13818-1 [17]) may be discontinuous.
- Adaptation headers shall not occur in TS packets identified by `PID 0x0000` (the PAT `PID`) for purposes other than for signaling with the `discontinuity_indicator` that the `version_number` (Section 2.4.4.5 of ISO/IEC 13818-1 [17]) may be discontinuous.
- Private table sections in addition to Program Map Tables may be present in TS packets `PMT_PID` identified by a `program_map_PID` value.

6.5 PES Constraints

Packetized Elementary Stream syntax and semantics as defined in [17] shall be used to encapsulate the audio and video elementary stream information defined in this specification. The

Packetized Elementary Stream syntax is used to convey the Presentation Time-Stamp (PTS) and Decoding Time-Stamp (DTS) information required for decoding audio and video information with synchronism. This Section describes the coding constraints for this system layer.

Within the PES packet header, the following restrictions shall apply:

- PES_scrambling_control shall be coded as '00'.
- ESCR_flag shall be coded as '0'.
- ES_rate_flag shall be coded as '0'.
- PES_CRC_flag shall be coded as '0'.

Within the PES packet extension, the following restrictions shall apply.

- PES_private_data_flag shall be coded as '0'.
- pack_header_field_flag shall be coded as '0'.
- program_packet_sequence_counter_flag shall be coded as '0'.
- P-STD_buffer_flag shall be coded as '0'.

6.5.1 Audio PES Constraints

The audio decoder may be capable of simultaneously decoding more than one audio elementary stream. In this case, the audio decoder may sequentially decode audio frames (or audio blocks) from each elementary stream and do the combining (mixing together) on a frame (or block) basis. In order to have the audio from the two elementary streams reproduced in exact sample synchronism, it is necessary for the original audio elementary stream encoders to have encoded the two audio program elements frame synchronously; i.e., if audio program 1 has sample 0 of frame n at time t_0 , then audio program 2 should also have frame n beginning with its sample 0 at the identical time t_0 . If the encoding is done frame-synchronously, then matching audio frames should have identical values of PTS.

If PES packets from two audio services that are to be decoded simultaneously contain identical values of PTS then the corresponding encoded audio frames contained in the PES packets should be presented to the audio decoder for simultaneous synchronous decoding. If the PTS values do not match (indicating that the audio encoding was not frame-synchronous) then the audio frames which are closest in time may be presented to the audio decoder for simultaneous decoding. In this case, the two services may be reproduced out-of-sync by as much as 1/2 of a frame time (which is often satisfactory; e.g., a voice-over does not require precise timing).

The value of stream_id for AC-3 audio shall be 1011 1101 (private_stream_1).

6.6 Specification of ATSC Private Data

Private Data shall be transported in accordance with Annex C of A/53B [4, 8].

6.7 Descriptors

Coding and transport of the AC-3 Audio Descriptor, Program Smoothing Buffer Descriptor, ISO-639 Language Descriptor, and ATSC Private Information Descriptor shall be in accordance with Annex C of A/53B [4, 8].

6.7.1 Video Stream Descriptor

Any elementary stream containing still picture data shall include a `video_stream_descriptor()` in accordance with ISO/IEC 13818-1 Sec. 2.6.2 [17] in the `TS_program_map_section` describing that elementary stream.

6.8 Audio Constraints

If a program contains one or more audio components, at least one shall be a complete main audio service (CM) as defined by ATSC Standard A/52A [3], including all voice-overs and emergency messages, when these are present in the Transport Stream.

7. VIDEO SUBSYSTEM SPECIFICATION

This section describes the characteristics and normative specifications for the Video Subsystem Standard for ATSC Satellite Broadcast system.

7.1 Possible Video Inputs

While not required by this standard, there are certain television production standards, shown in Table 7.1, that define video formats that relate to compression formats specified by this standard.

Table 7.1 Standardized Video Input Formats

Video Standard	Active Lines	Active Samples/Line
SMPTE 274M	1080	1920
SMPTE 296M	720	1280
ITU-R BT.601-5	483	720

The compression formats may be derived from one or more appropriate video input formats. It may be anticipated that additional video production standards will be developed in the future that extend the number of possible input formats.

7.2 Source Coding Specification

The video compression algorithm shall conform to the Main Profile syntax of ISO/IEC 13818-2 (2000) including Technical Corrigendum 1 [16, 18]. The allowable parameters shall be bounded by the upper limits specified for the Main Profile at High Level.² Additionally, bit streams shall meet the constraints and extensions described in Sections 7.3 and 7.4.

7.3 Constraints with Respect to ISO/IEC 13818-2 Main Profile

The following tables list the allowed values for each of the ISO/IEC 13818-2 [16, 18] syntactic elements. These values constrain what is specified by MP@HL.

In these tables conventional numbers denote decimal values, numbers preceded by 0x are to be interpreted as hexadecimal values and numbers within single quotes (e.g., '10010100') are to be interpreted as a string of binary digits.

² See ISO/IEC 13818-2, Section 8 for more information regarding profiles and levels.

7.3.1 Sequence Header Constraints

Table 7.2 identifies parameters in the sequence header of a bit stream that shall be constrained by the video subsystem and lists the allowed values for each.

Table 7.2 Sequence Header Constraints

Sequence Header Syntactic Element	Allowed Value
horizontal_size_value	See Table 7.3
vertical_size_value	See Table 7.3
aspect_ratio_information	See Table 7.3
frame_rate_code	See Table 7.3
bit_rate_value	$\leq 200,000$
Vbv_buffer_size_value	≤ 488

The allowable values for the field `bit_rate_value` are application-dependent. The maximum limit is 80 Mbps for MPEG-2 MP@HL.

7.3.2 Compression Format Constraints

The allowed compression formats shall be as listed in Table 7.3, and for 25/50 Hz video Table 3 in ATSC A/63 [5].

Table 7.3 Compression Format Constraints

vertical_size_ value	horizontal_size_ value	aspect_ratio_ information	frame_rate_ code	Progressive /Interlaced
1080	1280	3	1,2,4,5,7,8	P
1080	1280	3	4,5,7,8	I
1080	1920	1, 3	1, 2, 4, 5,7,8	P
1080	1920	1, 3	4, 5,7,8	I
1080	1440	3	1, 2, 4, 5,7,8	P
1080	1440	3	4, 5,7,8	I
720	1280	1, 3	1, 2, 4, 5, 7, 8	P
480	720	2, 3	1, 2, 4, 5, 7, 8	P
480	720	2, 3	4, 5	I
480	704	2, 3	1, 2, 4, 5, 7, 8	P
480	704	2, 3	4, 5	I
480	640	1, 2	1, 2, 4, 5, 7, 8	P
480	640	1, 2	4, 5	I
480	544	2	1	P
480	544	2	4	I
480	480	2	4,5	I
480	528	2	1	P
480	528	2	4	I
480	352	2	1	P
480	352	2	4	I
Legend for MPEG-2 Coded Values				
aspect_ratio_information: 1 = square samples, 2 = 4:3 display aspect ratio, 3 = 16:9 display aspect ratio				
frame_rate_code: 1 = 23.976 Hz, 2 = 24 Hz, 4 = 29.97 Hz, 5 = 30 Hz, 7 = 59.94 Hz, 8 = 60 Hz				
Progressive/Interlace: I= interlaced scan, P = progressive scan				

7.3.3 Sequence Extension Constraints

A `sequence_extension` shall be present immediately after each `sequence_header`. The `sequence_extension` shall conform to the constraints listed in Table 7.4.

Table 7.4 Sequence Extension Constraints

Sequence Extension Syntactic Element	Allowed Values
Progressive_sequence	See Table 3
Profile_and_level_indication	See Note
chroma_format	'01'
horizontal_size_extension	'00'
vertical_size_extension	'00'
bit_rate_extension	'0000 0000 0000'
Vbv_buffer_size_extension	'0000 0000'
Frame_rate_extension_n	'00'
Frame_rate_extension_d	'0000 0'

Note: The profile_and_level_indication field shall indicate the lowest profile and level defined in ISO/IEC 13818-2 [16, 18], Section 8, that is consistent with the parameters of the video elementary stream.

7.3.4 Sequence Display Extension Constraints

Table 7.5 identifies parameters in the sequence display extension part of a bit stream that shall be constrained by the video subsystem and lists the allowed values for each.

Table 7.5 Sequence Display Extension Constraints

Sequence Display Extension Syntactic Element	Allowed Values
video_format	'000'

The values for color primaries, transfer characteristics, and matrix coefficients shall be explicitly indicated in the sequence_display_extension. While all values for color primaries, transfer characteristics, and matrix coefficients defined in Tables 6-7, 6-8, and 6-9 of ISO/IEC 13818-2 [16, 18] are allowed in the transmitted bit stream, it is noted that ITU-R BT.709 [27] and SMPTE 170M are the most likely to be in common use.

Note: Some previously-encoded legacy material may not have the colorimetry (i.e., color primaries, transfer characteristics, and matrix coefficients) explicitly indicated in the sequence_display_extension, in which case the colorimetry is most likely ITU-R BT.709 for all formats except those formats with vertical_size_value = 480, which are most likely to have colorimetry according to SMPTE 170M.

7.3.5 Picture Coding Constraints

frame_pred_frame_dct shall be '1' if progressive_frame is '1'.

7.3.6 MPEG-2 Still Pictures

Certain services may include video elementary streams conforming to the ISO/IEC 13818-1 [17] Still Picture Model. Any elementary stream containing still picture data shall include a video_stream_descriptor() in accordance with ISO/IEC 13818-1 Sec. 2.6.2.

7.4 Bit Stream Specifications Beyond MPEG-2

This section covers the extension and user data part of the video syntax. These data are inserted at the sequence, GOP, and picture level and are used to carry advanced DTV closed captions, as well as NTSC closed captions and other data that might be present in the VBI of an NTSC signal.

7.4.1 Encoding and Transport of Advanced DTV Captions

Advanced DTV closed captions, when present, shall be encoded in accordance with EIA-708-B [12] and shall be transported in accordance with ATSC A/53B [4, 8] (note that advanced DTV captions are signaled in A/53B by setting the `cc_type` field to '10' or '11').

7.4.2 Encoding and Transport of NTSC Closed Captions

NTSC captions, when present, shall be encoded in accordance with EIA-608-B [9] and shall be transported in accordance with ATSC A/53B as modified by Amendment 1 [4, 8] (note that NTSC captions are signaled in A/53B by setting the `cc_type` field to '00' or '01'). NTSC captions may also be dual carried using the `video_user` data mechanism as defined in ANSI/SCTE 20 [1].

7.4.3 Encoding of Other NTSC VBI Data

For transport of other NTSC VBI data, see [1] and [2].

7.4.4 Encoding and Transport of Bar Data

Bar data, when present, shall be encoded and transported in accordance with ATSC A/53B [4] as modified by Amendment 1 to ATSC A/53B [8].

7.4.5 Encoding and Transport of Active Format Description Data

Active format description data, when present, shall be encoded and transported in accordance with ATSC A/53B [4, 8] as modified by Amendment 1 to ATSC A/53B.

8. AUDIO SUBSYSTEM SPECIFICATION

This section describes the characteristics and normative specifications for the Audio Subsystem Standard for ATSC Satellite Broadcast system.

8.1 Constraints with Respect to ATSC Standard A/52A

Audio compression shall conform with the Digital Audio Compression (AC-3) Standard, ATSC A/52A [3], subject to the constraints defined in A/53B with Amendment 1, Annex B [4, 8], except for the sampling frequency stipulated in Section 8.1.1.

8.1.1 Sampling Frequency

The sample rate shall be constrained to either 48 kHz or 44.1 kHz, corresponding to `fskod` values of '00' (48 kHz) and '01' (44.1 kHz), respectively.

8.1.2 Audio Coding Modes

This 3-bit audio coding mode, `acmod`, in A/52A [3], specified in Table 8.1, indicates which of the main service channels are in use. Note: the dual mono mode, `acmod` = 0, is not allowed.

Table 8.1 Audio Coding Mode

acmod	Audio Coding Mode	nfchans	Channel Array Ordering
'000'	Not allowed		
'001'	1/0	1	C
'010'	2/0	2	L, R
'011'	3/0	3	L, C, R
'100'	2/1	3	L, R, S
'101'	3/1	4	L, C, R, S
'110'	2/2	4	L, R, SL, SR
'111'	3/2	5	L, C, R, SL, SR

8.2 MPEG-1 Layer II Audio

MPEG-1 Layer II audio may be optionally carried within the same program. If present, this audio shall be signaled with `stream_type` value 0x03 in the Program Map Table.

9. PSIP SYSTEM

This section defines an extension to the A/65 Program and System Information Protocol standard [6] for satellite broadcasting applications. The syntax and semantics of [6] shall be followed unless otherwise constrained herein. Digital multiplex bit streams conformant to this specification are constructed in accordance with ISO/IEC 13818-1 (MPEG-2 Systems) [17]. The document defines the standard protocol for transmission of the relevant data tables contained within packets carried in the Transport Stream multiplex.

9.1 Overview

These sections describes tables that shall be applicable to satellite transmission systems. Some tables may be used in common with terrestrial broadcast and/or cable systems. The following tables shall be included in all ATSC-compliant Transport Streams to be transmitted via satellite broadcast:

- The Satellite Virtual Channel Table (SVCT) defining, at a minimum, the virtual channel structure for the collection of MPEG-2 programs embedded in the Transport Stream in which the SVCT is carried.
- The Master Guide Table (MGT) defining the type, packet identifiers, and versions for all of the other Satellite PSIP tables included in this Transport Stream, except for the System Time Table (STT).
- The Rating Region Table (RRT) defining the TV parental guideline system referenced by any content advisory descriptor carried within the Transport Stream, except the RRT corresponding to `rating_region` 0x01 (US + possessions).³

³ Note: Interpretation in a receiver of the `rating_region` 0x01 RRT requires prior knowledge of EIA/CEA-766-A [11]; therefore transmission is unnecessary. A future extension or replacement of the content advisory system for the US is possible by assignment of a new, different `rating_region` code and creation of new content for an RRT.

- The System Time Table (STT), defining the current date and time of day and daylight savings time transition timing.
- The first four Aggregate Event Information Tables (AEIT-0, AEIT-1, AEIT-2, and AEIT-3).

9.2 Data Structure

This section describes the data structure common to all satellite PSIP tables.

9.2.1 Table Format

Tables defined in this Standard are derived from the “long” form of the MPEG-2 `private_section` defined in sections 2.4.4.10 and 2.4.4.11 of ISO/IEC 13818-1 [17]. The table format common to all satellite PSIP tables is given in Table 9.1. An additional field, `protocol_version`, has been added immediately following the long-form header portion of the table section.

Table 9.1 Generic Table format used in Satellite PSIP

Syntax	No. of Bits	Format
PSIP_section() {		
table_id	8	uimsbf
section_syntax_indicator	1	'1'
private_indicator	1	'1'
reserved	2	'11'
section_length	12	uimsbf
table_id_extension	16	uimsbf
reserved	2	'11'
version_number	5	uimsbf
current_next_indicator	1	bslbf
section_number	8	uimsbf
last_section_number	8	uimsbf
protocol_version	8	uimsbf
PSIP_table_data()	*	
CRC_32	32	rpchof
}		

table_id — The value of this 8-bit field identifies the table this section belongs to. Tables defined in this Standard, and any created as user extensions to it are considered “private” with respect to ISO/IEC 13818-1.

Informative Table 9.2 lists Table ID ranges and values.

Table 9.2 Table ID Ranges and Values (Informative)

Table ID Value (hex)	Tables	PID	Reference
ISO/IEC 13818-1 Sections			
0x00	program association table (PAT)	0	[17]
0x01	conditional access table (CAT)	1	[17]
0x02	TS program map table (PMT)	per PAT	[17]
0x03	TS description table (TSDT)	2	[17]
0x04-0x3F	ISO Reserved or ISO Assigned		
User Private Sections			
0x40-0xBF	User private		
PSIP Tables			
0xC7	master guide table (MGT)	0x1FFB	Section 9.11.4
0xCA	rating region table (RRT)	0x1FFB	[6]
0xCD	system time table (STT)	0x1FFB	[6]
0xD6	aggregate event information table (AEIT)	per MGT	Section 9.11.2
0xD7	aggregate extended text table (AETT)	per MGT	Section 9.11.3
0xDA	satellite virtual channel table (SVCT)	per MGT	Section 9.11.1

section_syntax_indicator — This 1-bit field shall be set to ‘1’ to always indicate the “long” form of the MPEG-2 private_section table.

private_indicator — This 1-bit field shall be set to ‘1’.

private_section_length — A 12-bit field. It specifies the number of remaining bytes in the private section immediately following this field up to and including the CRC_32 field. The value in this field shall not exceed 4093 (0xFFD).

table_id_extension — This is a 16-bit field and is table-dependent. It shall be considered to be logically part of the table_id field providing the scope for the remaining fields.

version_number — This 5-bit field is the version number of the PSIP_section. The version_number shall be incremented by 1 modulo 32 when a change in the information carried within the PSIP_section occurs. When the current_next_indicator is set to '0', then the version_number shall be that of the next applicable PSIP_section() with the same table_id, table_id_extension, section_number, and protocol_version. When the current_next_indicator is set to '1', then the version_number shall be that of the current PSIP_section() with the same table_id, table_id_extension, section_number, and protocol_version.

current_next_indicator — A 1-bit field, which when set to ‘1’ indicates that the PSIP_section sent is currently applicable. When the current_next_indicator is set to '1', then the version_number shall be that of the currently applicable PSIP_section. When the bit is set to '0', it indicates that the PSIP_section sent is not yet applicable and shall be the next PSIP_section with the same section_number, table_id_extension, and table_id to become valid.

section_number — This 8-bit field gives the number of the PSIP_section. The section_number of the first section in a PSIP table shall be 0x00. The section_number shall be incremented by 1 with each additional section in PSIP table. The scope of the section_number shall be defined by the

table_id and table_id_extension. That is, for each PSIP table and value of the table_id_extension field, there is the potential for the full range of section_number values.

last_section_number — This 8-bit field specifies the number of the last section (that is, the section with the highest section_number) of the PSIP table of which this section is a part. Its scope is the same as for the section_number field.

protocol_version — An 8-bit unsigned integer field whose function is to allow, in the future, this table type to carry parameters that may be structured differently than those defined in the current protocol. At present, the only valid value for protocol_version is zero, but non-zero values may appear in the TS as the result of future standards activities. Non-zero values of protocol_version may be used by a future version of this standard to indicate structurally different tables.

CRC_32 — This is a 32-bit field that contains the CRC value that gives a zero output of the registers in the decoder defined in ISO/IEC 13818-1 [17], Annex A after processing the entire private section.

Note that individual PSIP tables defined in this Standard may further constrain the above fields. But when not further constrained in each table, the above semantics shall apply.

9.3 Extensibility

The PSIP protocol describes a number of tables conveying system information and content guide data structures. The Standard is designed to be extensible via the following mechanisms:

- **Reserved fields:** Fields in this Standard marked reserved shall be reserved for use either when revising this Standard, or when another standard is issued that builds upon this one.
- **Standard table types:** An extension or update to this Standard can define a new table type with a table_id value assigned by the ATSC registrar.
- **Protocol Version Field:** Initially this field is set to 0, but after approval, future structural modifications shall be accommodated by defining different protocol version numbers.

9.4 User Private Ranges

Certain fields in this Standard are defined to include “user private” ranges.

9.4.1 table_id values in the range 0x40 through 0xBF

Table sections with table_id values in the user private range (0x40 through 0xBF) shall not appear in transport packets identified with the satellite base_PID PID value (0x1FFB). The MGT may refer to private table sections with any value of table_id including values in the user private range.

9.5 Reserved Fields

Fields in this Satellite PSIP Standard marked “reserved” shall not be assigned by the user, but shall be available for future use. Decoders are expected to disregard reserved fields for which no definition exists that is known to that unit. Each bit in the fields marked “reserved” shall be set to one until such time as they are defined and supported.

9.6 Table Hierarchy and Structure Requirements

The Program and System Information Protocol for satellite applications is a collection of hierarchically arranged tables for describing system information and program guide data. These tables are packetized and multiplexed according to the transport protocol detailed in ISO/IEC 13818-1 [17].

The base PID (*base_PID*) is an explicitly defined value (0x1FFB) used to identify the packets for the following tables: The System Time Table (STT), the Master Guide Table (MGT), and the Rating Region Table (RRT). The MGT gives PID values used to transport sections of the Satellite Virtual Channel Tables (SVCT), Aggregate Event Information Tables (AEITs), and Aggregate Extended Text Tables (AETTs). Figure 9.1 illustrates the relations between these elements.

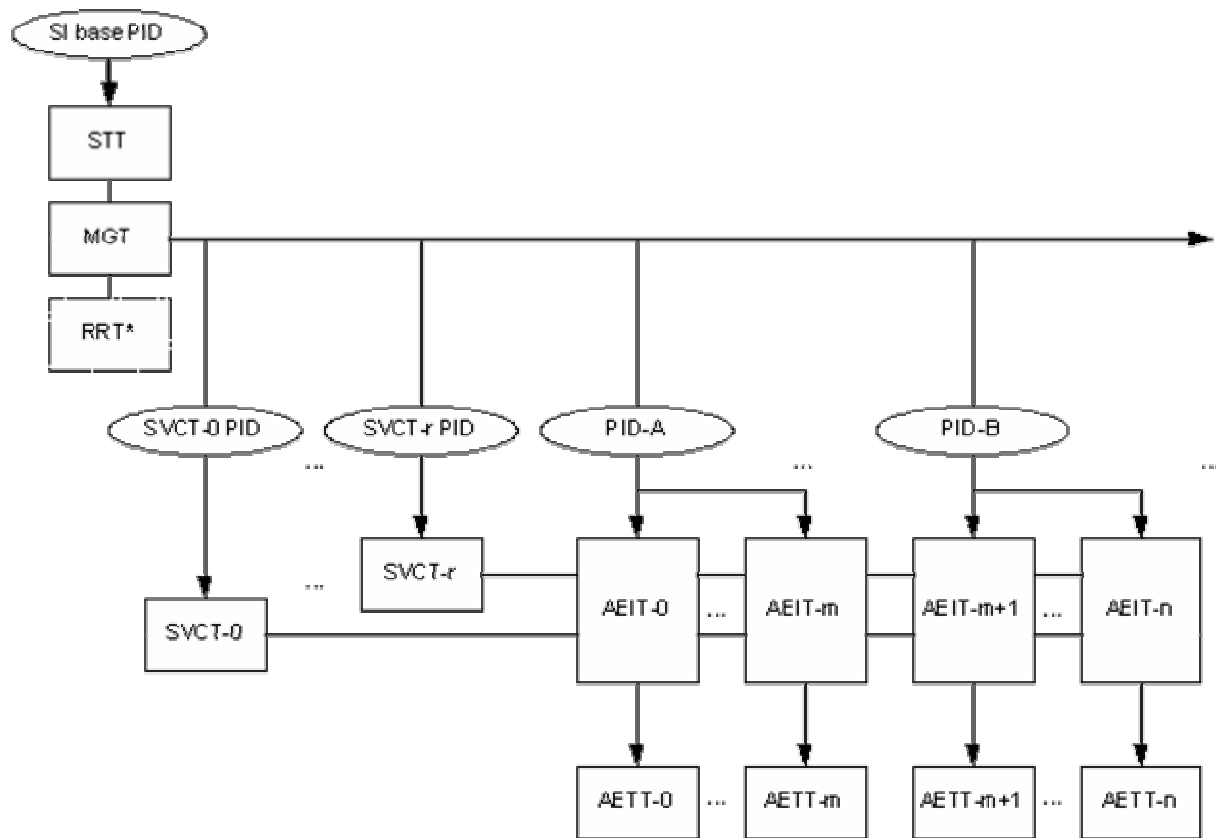

Figure 9.1 Table hierarchy for Satellite PSIP

In Figure 9.1, multiple SVCTs are transmitted, labeled SVCT-0 through SVCT-*r* where the number following the dash is given by the *SVCT_id* parameter. As shown, each is carried in TS packets identified with a different value of PID. There is no restriction on PID values that prevents SVCT-*m* from appearing in TS packets with the same PID value as SVCT-*n* for any values of *m* and *n*.

The figure also shows that one or more AEIT instances can appear in TS packets with the same PID value as other AEIT instances. The same applies for AETT instances. PID assignment for any AEIT or AEIT (any time slot) is totally flexible and unconstrained.

As the name indicates, the System Time Table (STT) carries time information needed for any application requiring synchronization. The Rating Region Table (RRT) defines rating tables valid for different regions or countries. The Master Guide Table (MGT) defines sizes, PIDs, and version numbers for all of the relevant tables.

The purpose of the Satellite Virtual Channel Table (SVCT) is to tabulate virtual channel attributes required for navigation and tuning. The SVCT is similar in structure to the Cable and Terrestrial VCTs defined in ATSC Standard A/65 [6]. In the satellite application, more than one different SVCT may be present in the same Transport Stream. Any given receiver can make use of one or more of the available SVCTs for tuning and navigation. The mechanism for selection of relevant SVCTs is outside the scope of this standard.

Each of the Aggregate Event Information Tables (AEITs) lists TV programs (events) for the virtual channels described in the SVCT. The AEITs are organized from AEIT-0 to AEIT-255. The first table (AEIT-0) corresponds to the currently valid list of events. The second table (AEIT-1) corresponds to the next 3-hour time window, and so on.

During remultiplexing, AEIT tables which originally existed in separate Transport Streams may be multiplexed into a common Transport Stream or vice versa. For this reason, it is very convenient to synchronize the start times and durations of the AEITs. Consequently, the following three synchronization rules shall be followed when AEIT tables are prepared.

- **Requirement 1:** Each AEIT shall have a duration of 3 hours.
- **Requirement 2:** Start times for AEITs are restricted to 0:00 (midnight), 3:00, 6:00, 9:00, 12:00 (noon), 15:00, 18:00, and 21:00. All of these times are UTC.
- **Requirement 3:** AEIT-0 lists all of the available events for the current 3-hour time segment. AEIT-1 lists all of the available events for the next 3-hour time segment, and likewise, non-overlapping sequential time windows are allocated for all of the other AEITs.

For example, a broadcast group operating in the Eastern time zone of the U.S. at 15:30 EDT (19:30 UTC) is required to carry AEIT-0 describing events from 14:00 to 17:00 EDT (18:00 to 21:00 in UTC time) plus AEIT-1, AEIT-2, and AEIT-3 covering the next 9-hour interval between 17:00 to 2:00 EDT. At 17:00 EDT, the first table, AEIT-0, will be obsolete while AEIT-1 will still be valid. At this time, simply by shifting the listed PID values in the MGT, AEIT-1 becomes AEIT-0 and AEIT-2 becomes AEIT-1. Updating tables then becomes a process of shifting the list of PIDs in the MGT and their corresponding version numbers. However, updates and/or corrections to the information in the AEITs may be performed at any time since the decoder monitors the MGT continuously, where the most current copy of the version number is maintained. Updates and/or corrections to the AEIT (other than shifting) shall be signaled by increasing the version number by one.

Besides listing the PIDs for all of the AEITs, the Master Guide Table (MGT) also lists a set of PIDs for Aggregate Extended Text Tables (AETTs). These tables carry relatively long text messages for describing events and virtual channels. Each AEIT has either zero or one associated AETT. Similarly, The SVCT has either zero or one associated AETT.

9.7 Requirements for Satellite Broadcast

The rules governing the transport of PSIP tables for satellite are:

- **Requirement 4:** Every digital Transport Stream delivered via satellite shall include the STT, one or more SVCTs, the MGT and the first four Aggregate Event Information Tables (AEIT-0, AEIT-1, AEIT-2 and AEIT-3). For any region that makes use of the capability to change the RRT, that RRT shall be included in the TS if any content_advisory_descriptor in use refers to that region. For regions (such as the U.S.) where the definition of the rating system involves more information than the RRT conveys, transmission of that region's RRT is not required and is not recommended.
- **Requirement 5:** The PSIP tables shall describe all of the digital channels multiplexed in the Transport Stream. For convenience, the tables may optionally include information about other digital channels available in different satellite Transport Streams.

9.8 Code points defined in this Standard

The following code points are defined in this Standard:

- table_id value 0xDA, identifying the Satellite Virtual Channel Table
- MGT table_type values 0x1600 to 0x16FF used to reference instances of the SVCT

9.9 Specifications

This section describes the bit stream syntax and semantics for the Satellite Virtual Channel Table (SVCT), the Aggregate Event Information Table (AEIT), and the Aggregate Extended Text Table (AETT). The syntax and semantics for the System Time Table (STT), Master Guide table (MGT), Rating Region Table (RRT), descriptors, and the Multiple String Structure can be found in [6]. An extension to the MGT to allow it to refer to instances of the SVCT is defined in Section 9.9.4.

9.9.1 Satellite Virtual Channel Table (SVCT)

The Satellite Virtual Channel Table (SVCT), like its cable and terrestrial broadcast counterparts, contains a list of attributes for virtual channels carried in the Transport Stream. Any changes in the virtual channel structure shall be conveyed with a new version number. The basic information contained in the body of the SVCT includes Transport Stream ID, major and minor channel number, short channel name, carrier frequency, program number, location field for extended text messages, service type, and modulation parameters. Additional information may be carried by descriptors, which may be placed in the descriptor loop after the basic information.

Unlike cable and terrestrial applications where just one Virtual Channel Table is present in any given Transport Stream, in the satellite application more than one may be present. Different SVCTs are distinguished from one another by the SVCT_id parameter in the MPEG header portion of the table section. A receiver is expected to capture and record one or more SVCTs for use in navigation and service acquisition. At least one SVCT in each Transport Stream (and maybe more than one) will be applicable to a given receiving device. The mechanism by which a receiver knows which SVCT_id values correspond to tables of interest and which are of no value is typically tied to the Conditional Access function and is outside the scope of this standard.

The Satellite Virtual Channel Table may be segmented into as many as 256 sections. One section may contain information for several virtual channels, but the information for one virtual channel shall not be segmented and put into two or more sections. Thus for each section, the first field after protocol_version shall be num_channels_in_section.

The Satellite Virtual Channel Table is carried in private sections with table ID 0xDA, and obeys the syntax and semantics given in Section 4. The following constraints apply to the Transport Stream packets carrying the SVCT sections:

- PID for a given instance of an SVCT shall have the value given by the MGT for that instance, as identified by its SVCT_id.
- transport_scrambling_control bits shall have the value '00'
- adaptation_field_control bits shall have the value '01'

The bit stream syntax for the Satellite Virtual Channel Table is shown in Table 9.3. The semantics for the SVCT are the same as the TVCT in [6] except for those fields explicitly defined below.

Table 9.3 Bit Stream Syntax for the Satellite Virtual Channel Table

Syntax	No. of Bits	Format
satellite_virtual_channel_table_section () {		
table_id	8	0xDA
section_syntax_indicator	1	'1'
private_indicator	1	'1'
reserved	2	'11'
section_length	12	uimsbf
SVCT_subtype	8	uimsbf
SVCT_id	8	uimsbf
reserved	2	'11'
version_number	5	uimsbf
current_next_indicator	1	bslbf
section_number	8	uimsbf
last_section_number	8	uimsbf
protocol_version	8	uimsbf
num_channels_in_section	8	uimsbf
for(i=0; i<num_channels_in_section;i++) {		
short_name	8*16	uimsbf
reserved	4	'1111'
major_channel_number	10	uimsbf
minor_channel_number	10	uimsbf
modulation_mode	6	uimsbf
carrier_frequency	32	uimsbf
carrier_symbol_rate	32	uimsbf
polarization	2	uimsbf
FEC_Inner	8	uimsbf
channel_TSID	16	uimsbf
program_number	16	uimsbf
ETM_location	2	bslbf
reserved	1	'1'

Syntax	No. of Bits	Format
hidden	1	bslbf
reserved	2	'11'
hide_guide	1	bslbf
reserved	3	'111'
service_type	6	uimsbf
source_id	16	uimsbf
feed_id	8	uimsbf
reserved	6	'111111'
descriptors_length for (i=0; i<N; i++) { descriptors() }	10	uimsbf
reserved	6	'111111'
additional_descriptors_length for(j=0; j<N; j++) { additional_descriptors() }	10	uimsbf
CRC_32	32	rpchof

table_id — An 8-bit unsigned integer number that indicates the type of table section being defined here. For the `satellite_virtual_channel_table_section()`, the `table_id` shall be 0xDA.

SVCT_subtype — An 8-bit unsigned integer number that indicates the type of Satellite Virtual Channel Table. At present, the only defined subtype is type zero. Receivers are expected to discard the table section if `SVCT_subtype` is non-zero.

SVCT_id — An 8-bit unsigned integer number that identifies this instance of the SVCT table section with a particular collection of virtual channel records. Any given receiver may collect virtual channel records associated with one or more values of `SVCT_id`, depending upon that receiver's authorization to receive services. The mechanism that determines exactly which sets should be collected by a given receiver and which sets are of no value is outside the scope of this standard.

short_name — The name of the virtual channel represented as a sequence of one to eight 16-bit code values interpreted in accordance with the UTF-16 representation of Unicode character data. If the length of the name requires fewer than eight 16-bit code values, then this field shall be padded out to eight 16-bit code values using the Unicode NUL character (0x0000). Unicode character data shall conform to The Unicode Standard, Version 3.0 [19]. The UTF-16 representation of Unicode character data is in accordance with that defined by [19], which is identical to that defined by ISO/IEC 10646-1:2000 Annex C [15].

major_channel_number, minor_channel_number — These two 10-bit fields represent either a two-part or a one-part virtual channel number associated with the virtual channel being defined in this iteration of the "for" loop. One-part numbers range from 0 to 16,383. Two-part numbers

consist of a major and a minor number part; the range of each is 0 to 999. The one- or two-part number acts as the user's reference number for the virtual channel. Some channels may be represented with a one-part number, while others in the SVCT are represented with two-part numbers.

The six MSBs of the `major_channel_number` field, when all 1, indicate that a one-part number is being specified. The value of the one-part number is given, in C syntax, by:

$$\text{one_part_number} = (\text{major_channel_number} \& 0x00F) \ll 10 + \text{minor_channel_number}$$

When the six MSBs of the `major_channel_number` field are not all 1, and the 10-bit `major_channel_number` field is less than 1000, two fields specify a two-part channel number. The value of the two-part number is given by `major_channel_number` and `minor_channel_number`.

modulation_mode — A 6-bit unsigned integer number that indicates the modulation mode for the transmitted carrier associated with this virtual channel. Values of `modulation_mode` are defined by this standard in Table 9.4. For digital signals, the standard values for modulation mode (values below 0x3F) indicate transport framing structure, channel coding, interleaving, channel modulation, forward error correction, symbol rate, and other transmission-related parameters, by means of a reference to an appropriate standard. A value of 0x3F for `modulation_mode` indicates that modulation parameters are defined by an ATSC Private Information Descriptor in the descriptor loop for the particular virtual channel. The `format_identifier` in the ATSC Private Information Descriptor shall be registered with the registration authority authorized by MPEG, currently the Society of Motion Picture and Television Engineers (SMPTE) (see <http://www.smp-te-ra.org/>).

Table 9.4 Modulation Modes

Modulation Mode	Meaning
0x00	Forbidden.
0x01	QPSK – The virtual channel uses the QPSK modulation method conforming to Rec. ITU-R BO.1516 System C.
0x02	BPSK – The virtual channel uses BPSK modulation.
0x03	OQPSK – The virtual channel uses OQPSK modulation.
0x04	Reserved for future use.
0x05	Reserved for future use.
0x06	Modulation mode not specified.
0x07	QPSK, The virtual channel uses the QPSK modulation method conforming to the ETS 300-421 [13].
0x08	8PSK, The virtual channel uses the 8-PSK modulation method conforming to ATSC A/80 [7].
0x09	16PSK, The virtual channel uses the 16-PSK modulation method conforming to .ATSC A/80 [7].
0x0A	16QAM—The virtual channel uses the 16QAM modulation method conforming to ATSC A/80 [7].
0x0B – 0x3E	Reserved for future use.
0x3F	Modulation parameters are defined by an ATSC Private Information Descriptor

carrier_frequency — A 32-bit unsigned integer that represents the carrier frequency associated with the analog or digital transmission associated with this virtual channel, in units of 100 Hz. The

given carrier frequency shall be relative to the point in the receiver following block conversion of the downlink signal; i.e., at the L-band input to the receiver. Typical satellite tuners are able to lock to a carrier within 1 MHz of any center frequency specified. An inaccuracy of 100 Hz will not cause any loss in functionality in satellite reception.

carrier_symbol_rate — A 32-bit unsigned integer that represents the carrier symbol rate associated with a digital carrier, in units of one symbol per second.

polarization — A 2-bit unsigned integer that represents the polarization according to Table 9.5.

Table 9.5 Polarization Coding

Polarization	Meaning
0	Linear - horizontal
1	Linear - vertical
2	Circular - left
3	Circular - right

FEC_inner — An 8-bit unsigned integer that represents the Viterbi puncture rate to be used in the digital carrier. The applicable puncture rates are given in Table 9.6.

Table 9.6 FEC_inner Coding

FEC_inner	Meaning
0	Not specified
1	rate 5/11 coding
2	rate 1/2 coding
3	Reserved
4	3/5 FEC rate
5	Reserved
6	2/3 FEC rate
7	Reserved
8	3/4 FEC rate
9	4/5 FEC rate
10	5/6 FEC rate
11	6/7 FEC rate
12	7/8 FEC rate
13	8/9 FEC rate
14 – 254	reserved
255	No concatenated coding

channel_TSID — A 16-bit unsigned integer field, in the range 0x0000 to 0xFFFF, that represents the MPEG-2 Transport Stream ID associated with the Transport Stream carrying the MPEG-2 program referenced by this virtual channel. For inactive channels, channel_TSID represents the ID of the Transport Stream that will carry the virtual channel when it becomes active.

The receiving device may use the channel_TSID to verify that a TS acquired is actually the desired multiplex. The satellite service provider shall ensure that the MPEG-2 Transport Stream ID for each MPEG-2 TS in the network is unique.

source_ID — A 16-bit unsigned integer number that identifies the programming source associated with the virtual channel. In this context, a *source* is one specific source of video, text, data, or audio programming. Source ID value zero is reserved to indicate that the programming source is not identified. Source ID values in the range 0x0001 to 0x0FFF shall be unique within the Transport Stream that carries the SVCT, while values 0x1000 to 0xFFFF shall be unique at the service-provider (network) level. Values for *source_ids* 0x1000 and above shall be issued and administered by a Registration Authority designated by the ATSC.

feed_id — An 8-bit unsigned integer that indicates the physical satellite or polarization feed associated with this virtual channel. The relationship between values of *feed_id* and the corresponding physical signal path is outside the scope of this standard. Each feed may correspond to a different satellite, but *feed_id* could be used to select polarizations or frequency bands.

9.9.2 Aggregate Event Information Tables (AEIT)

The Aggregate Event Information Table delivers event title and schedule information that may be used to support an Electronic Program Guide application. The transmission format allows instances of table sections for different time periods to be associated with common PID values. The Aggregate Event Information Table obeys the syntax and semantics of PSIP tables given in Section 4.

Each AEIT instance describes event data for one three-hour time period. The start time for any AEIT is constrained to be one of the following eight UTC times: 00:00 (midnight), 03:00, 06:00, 09:00, 12:00 (noon), 15:00, 18:00, and 21:00.

The notation AEIT-*n* refers to the AEIT corresponding to timeslot *n*. Value 0 for *n* indicates the current timeslot, value 1 the next timeslot, etc. The same notational methods apply to AETT.

Except for AEIT-0, each AEIT instance may omit event data for those events that started in a prior time period.⁴ AEIT-0 shall also include event data for all events starting in a prior timeslot but continuing into the current timeslot. In addition, if the SVCT entry for a particular source ID includes a *time_shifted_service_descriptor()*, AEIT-0 shall describe event data for active events on any channels referenced through the *time_shifted_service_descriptor()*.

ETMs for events described in AEIT-0 shall be provided in AETT-0 on the PID associated with AETT-0 until they are no longer referenced by AEIT-0.

Table 9.7 defines the syntax of the Aggregate Event Information Table.

⁴ Although AEIT is similar in structure to the EIT in ATSC A/65, its properties differ from EIT in this regard.

Table 9.7 Aggregate Event Information Table format

Syntax	No. of Bits	Format
aggregate_event_information_table_section () {		
table_id	8	0xD6
section_syntax_indicator	1	'1'
private_indicator	1	'1'
reserved	2	'11'
section_length	12	uimsbf
AEIT_subtype	8	uimsbf
MGT_tag	8	uimsbf
reserved	2	'11'
version_number	5	uimsbf
current_next_indicator	1	'1'
section_number	8	uimsbf
last_section_number	8	uimsbf
if (AEIT_subtype == 0) {		
num_sources_in_section	8	uimsbf
for (j = 0; j < num_sources_in_section; j++) {		
source_id	16	uimsbf
num_events	8	uimsbf
for (j = 0; j < num_events; j++) {		
off_air	1	bslbf
reserved	1	'1'
event_id	14	uimsbf
start_time	32	uimsbf
reserved	4	'1111'
duration	20	uimsbf
title_length	8	uimsbf
title_text()	var	
reserved	4	'1111'
descriptors_length	12	
for (i=0; i < N; i++) {		
descriptor()		
}		
}		
}		
} else		
reserved	n*8	
CRC_32	32	rpchof
}		

table_id — The `table_id` of the Aggregate Event Information Table shall be 0xD6.

AEIT_subtype — This 8-bit field identifies the subtype of the AEIT. In the current protocol, only table subtype value 0x00 is defined. Host devices shall discard instances of the `aggregate_event_information_table_section()` in which an unknown `AEIT_subtype` is specified (currently, any value other than zero).

MGT_tag — An 8-bit field that ties this AEIT instance to the corresponding `table_type` in the MGT and to an AETT instance with the same value. The `MGT_tag` value for an AEIT instance for a given timeslot shall be one higher (modulo 256) than the instance for the preceding time period.

version_number — This 5-bit field is the version number of the AEIT instance. An instance is identified by a certain value of `MGT_tag`, `MGT_subtype`, `section_number`, and `protocol_version`. The version number shall be incremented by 1 modulo 32 when any field in the AEIT instance changes. The value of this field shall be identical to that of the corresponding entry in the MGT.

current_next_indicator — This 1-bit indicator is always set to ‘1’ for AEIT sections; the AEIT sent is always currently applicable.

section_number — This 8-bit field gives the number of this section.

last_section_number — This 8-bit field specifies the number of the last section.

num_sources_in_section — This 8-bit field gives the number of iterations of the “for” loop describing program schedule data.

source_id — This 16-bit field specifies the `source_id` of the virtual channel carrying the events described in this section.

num_events — Indicates the number of events to follow associated with the program source identified by `source_id`. Value 0 indicates no events are defined for this source for the time period covered by the AEIT instance.

event_id — This 14-bit field specifies the identification number of the event described. This number serves as a part of the event `ETM_id` (identifier for event Extended Text Message). An assigned `event_id` shall be unique at least within the scope of the instance of the AEIT in which it appears. Accordingly, as an example, the event associated with `event_id` 0x0123 in AEIT-*m* shall be considered to be an event distinct from `event_id` 0x0123 in AEIT-*n*, when *m* is not equal to *n*.

off_air — A flag that indicates, when set that the virtual channel(s) referenced by the `source_id` is off the air during the period of time indicated by `start_time` and `duration`. When the `off_air` flag is false, the service is scheduled to be transmitting normally.

start_time — A 32-bit unsigned integer quantity representing the start time of this event as the number of seconds since 0000 Hours UTC, January 6th, 1980. If the `GPS_UTC_offset` delivered in the System Time Table is zero, `start_time` includes the correction for leap seconds. Otherwise, `start_time` can be converted to UTC by subtracting the `GPS_UTC_offset`.

duration — Duration of this event in seconds.

title_length — This field specifies the length (in bytes) of the `title_text()`. Value 0 means that no title exists for this event.

title_text() — The event title in the format of a Multiple String Structure. `title_text()` shall be formatted according to the Multiple String Structure in Section 6.8 of [6].

descriptors_length — Total length (in bytes) of the event descriptor list that follows.

9.9.3 Aggregate Extended Text Tables (AETT)

The Aggregate Extended Text Table contains Extended Text Messages (ETM), which are used to provide detailed descriptions of events. An ETM is a multiple string data structure. Thus, it may represent a description in several different languages (each string corresponding to one language). If necessary, the description may be truncated to fit the allocated display space. The Aggregate Extended Text Table obeys the syntax and semantics of PSIP tables given in Section 4.

The transmission format of the AETT and its affiliated AEIT allows instances of AEIT/AETT table sections for different time slots to be associated with common PID values.

A program element for AETT-*n* and a program element for AEIT-*n* shall share a common PID value, for a given value of *n*.

The Aggregate Extended Text Table is carried in an MPEG-2 private section with table_id 0xD7. An instance of the AETT includes one or more ETMs. Each description is distinguished by its unique 32-bit ETM_id.

Table 9.8 defines the syntax of the Aggregate Extended Text Table.

Table 9.8 Aggregate Extended Text Table Format

Syntax	No. of Bits	Format
aggregate_extended_text_table_section () {		
table_id	8	0xD7
section_syntax_indicator	1	'1'
private_indicator	1	'1'
reserved	2	'11'
section_length	12	uimsbf
AETT_subtype	8	uimsbf
MGT_tag	8	uimsbf
reserved	2	'11'
version_number	5	uimsbf
current_next_indicator	1	'1'
section_number	8	uimsbf
last_section_number	8	uimsbf
if (AETT_subtype == 0) {		
num_blocks_in_section	8	uimsbf
for (j = 0; j < num_blocks_in_section; j++) {		
ETM_id	32	uimsbf
reserved	4	'1111'
extended_text_length	12	uimsbf
extended_text_message()	var	
}		
}		
else		
reserved	n*8	
CRC_32	32	rpchof
}		

table_id — The table_id of the Aggregate Extended Text Table shall be 0xD7.

AETT_subtype — This 8-bit field identifies the subtype of the AETT. In the current protocol, only table subtype value 0x00 is defined. Host devices shall discard instances of the aggregate_extended_text_table_section() in which an unknown AETT_subtype is specified (currently, any value other than zero).

MGT_tag — An 8-bit field that ties this AETT instance to the corresponding table_type in the MGT and to an AEIT instance with the same value. The MGT_tag value for an AETT instance for a given time period shall be one higher (modulo 256) than the instance for the preceding time period.

version_number — This 5-bit field is the version number of the AETT instance. An instance is identified by a certain value of MGT_tag, MGT_subtype, section_number, and protocol_version. The version number shall be incremented by 1 modulo 32 when any field in the AEIT instance

changes. The value of this field shall be identical to that of the corresponding entry in the MGT.

current_next_indicator — This 1-bit indicator is always set to ‘1’ for AETT sections; the AETT sent is always currently applicable.

section_number — This 8-bit field gives the number of this section.

last_section_number — This 8-bit field specifies the number of the last section.

num_blocks_in_section — This 8-bit field gives the number of iterations of the “for” loop describing ETM data.

ETM_id — Unique 32-bit identifier of this Extended Text Message. This identifier is assigned by the rule shown in Table 9.9.

Table 9.9 ETM ID

	MSB				LSB	
Bit	31	16	15	2	1	0
event ETM_id	source_id		event_id		1	0

extended_text_length — A 12-bit unsigned integer number that represents the length, in bytes, of the `extended_text_message()` field directly following.

extended_text_message() — The extended text message in the format of a Multiple String Structure defined in Section 6.8 of [6].

9.9.4 Master Guide Table (MGT)

9.9.4.1 Table References

The `table_type` values applicable for the satellite application are indicated in Table 9.10.

Table 9.10 MGT Table Types for Satellite Application

table_type	Meaning
0x1000 – 0x10FF	Aggregate Event Information Table with MGT_tag 0 to 255
0x1100 – 0x11FF	Aggregate Extended Text Table with MGT_tag 0 to 255
0x1600 – 0x16FF	Satellite Virtual Channel Table with SVCT_id 0 to 255

9.9.4.2 Restrictions on Order of Occurrence of Table References

MGT table types 0x1000 through 0x10FF reference AEIT instances with MGT_tag values 0x00 through 0xFF, respectively. Table types 0x1100 through 0x11FF reference AETT instances with MGT_tag values 0x00 through 0xFF, respectively. A `table_type` value of 0x1023 in the MGT, for example, refers to the instance of the AEIT with MGT_tag value 0x23. Note that the choice of value of the MGT_tag is independent of the timeslot number. For example, the MGT_tag value used to deliver AEIT-0 may be zero or any other value up to 255.

9.9.4.3 Restrictions on Order of Occurrence of Table References

For all table references except AEIT and AETT, the order of appearance in the MGT of various table references is not specified or restricted. For AEIT and AETT references, the following restriction applies:

The order of appearance of AEIT/AETT references in the MGT shall correspond to increasing time slot assignments.

Note: this rule allows a receiver to know, before processing the AEIT/AETT data, which table instances correspond to near-term data and which correspond to data farther into the future. This information is useful if the receiver has insufficient RAM to hold all data transmitted.

9.9.5 Core Descriptors

Table 9.11 indicates all the core descriptors, their tags, and their allowed locations in the satellite PSIP tables. Table 9.11 does not specify the rules governing whether or not a particular descriptor must be present in any given situation. When used, some descriptors shall be placed in each indicated location (shown with an “M”). Some descriptors also may be present in a second location (shown with an “O”). Asterisks mark the tables where the descriptors may appear without restrictions.

Table 9.11 List of Descriptors for Satellite PSIP Tables

Descriptor Name	Descriptor Tag	PMT	MGT	SVCT	AEIT	TSDT	DCCT	DCCSCT
ISO-639 language descriptor	0x0A	M			O			
stuffing descriptor	0x80	*	*	*	*	*	*	*
AC-3 audio descriptor	0x81	M			O			
caption service descriptor	0x86	M			O			
content advisory descriptor	0x87	M			O			
extended channel name descriptor	0xA0			M				
time-shifted service descriptor	0xA2			M				
component name descriptor	0xA3	M						
DCC Departing Request Descriptor	0xA8						M	
DCC Arriving Request Descriptor	0xA9						M	
DCC Location Code Descriptor	0xAB							M
Redistribution Control Descriptor	0xAA	M			M			

Note: User-private descriptors appearing in the SVCT shall require an accompanying MPEG Registration Descriptor.

9.9.6 PSIP STD Model Constraints

9.9.6.1 Buffer Model for Satellite

The recommended buffer model is that of the Terrestrial Broadcast system. Table 9.12 lists the maximum cycle time for all PSIP tables, except AETTs. Table 9.13 lists the maximum transmission rate for PSIP packet streams according to their PIDs. The recommended maximum cycle time for AEIT-0 is 500 ms.

Table 9.12 Maximum cycle time for the STT, MGT, SVCT and RRT

Table	STT	MGT	SVCT	RRT (when present)
Cycle time (ms)	1000	150	400	60000

Table 9.13 Maximum Rate for Each PSIP Packet Stream

PID	base_PID	AEIT_PID	AETT_PID
Rate (bps)	250,000	250,000	250,000

For satellite applications the following constraints apply. Transport Stream packets with PID 0x1FFB (base_PID), AEIT PIDs and AETT PIDs shall adhere to an STD model with the following parameters:

- sb_leak_rate shall be 625 (indicating a leak rate of 250,000 bps)
- sb_size shall be 1024 (indicating a smoothing buffer size of 1024 bytes)

10. CONDITIONAL ACCESS SUBSYSTEM

Service Provider may use existing or future Conditional Access subsystem that complies with other subsystems defined in this document.